

LEMKEN

Semi-mounted reversible ploughs EuroTitan and Vari-Titan



LEMKEN EuroTitan and Vari-Titan

The concept

Continuous growth of farm size leads to ever-increasing demands being made on modern semi-mounted reversible ploughs. Among the forces maintaining continuous farmer interest in large-capacity plough capability are yield potential, rainfall and differing crop rotations.

Meeting practical farming's high demands in every way regarding operation, work quality, productivity increases and, not least, cost reductions are the Euro Titan and Vari-Titan ploughs from LEMKEN.

The Vari-Titan semi-mounted reversible plough

The Vari-Titan from LEMKEN allows stepless hydraulic furrow width adjustment from 30 to 55 cm, meaning total working widths of 270 to 660 cm from nine to 12 furrows.

The plough is available with automatic no-stop overload safety system. This semi-mounted reversible plough can be used on-land or in the furrow.

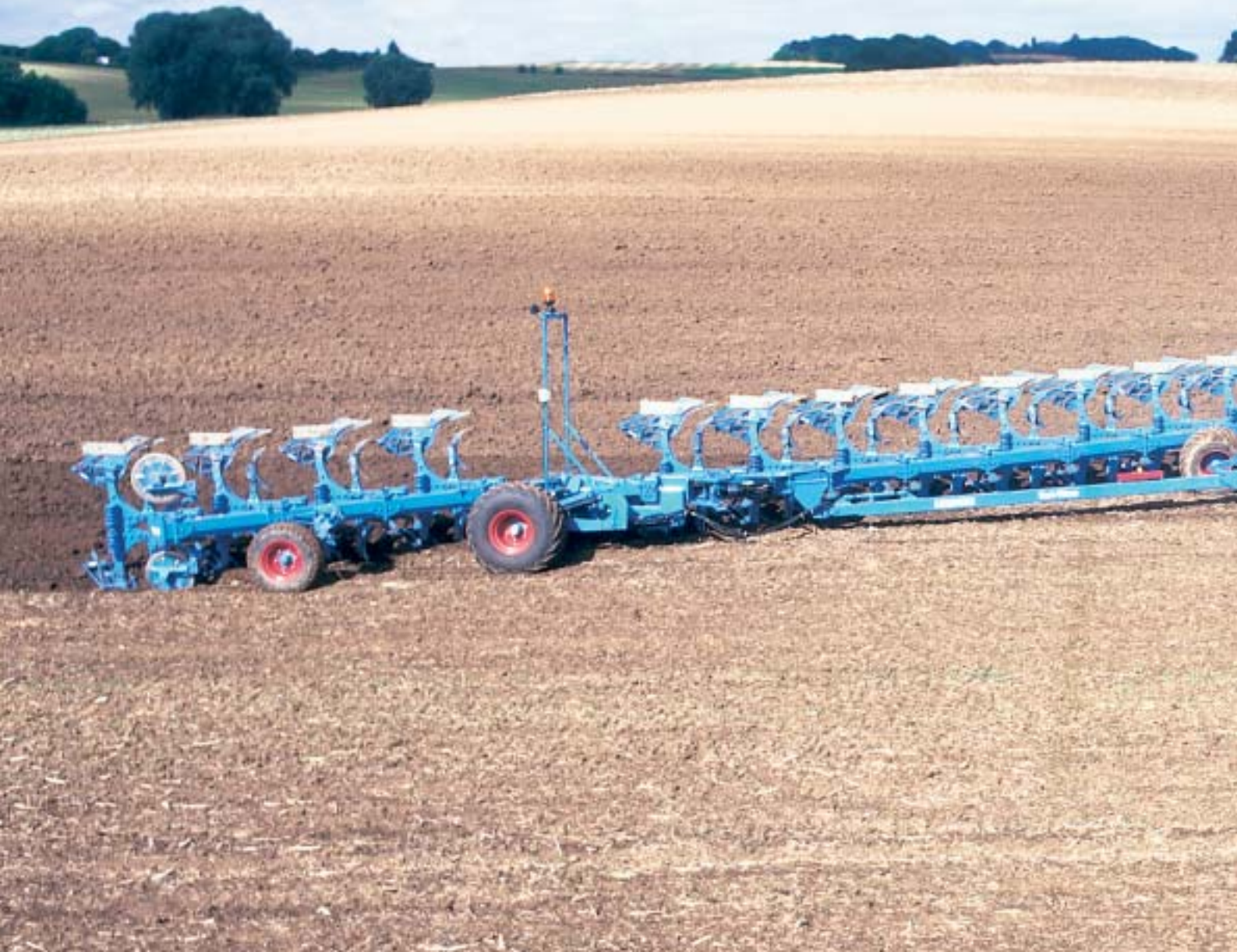

A new performance dimension

Capability profile

- The plough is exceptionally manoeuvrable for rapid turning on narrow headlands to give highest area-performances.
- The simply-adjusted working width on the Vari-Titan copes with differing soils and weather conditions and offers an important contribution to ecological and economical crop production.
- The strength of the plough meets the demands of increasing tractor draught forces and greater working widths.
- Semi-mounted ploughs have to be usable with much wider tractors and with on-land systems. Draught forces of over 300 PS mean conventional tyre widths are right at their limit which brings more dual wheels or track layers with which ploughs can be operated on-land.
- Adjustment of skimmers is rapid and simple, requiring no tools.
- Road journeys are safe. High speeds are possible. Tractor stress is low.
- Longer working life of wearing parts lead to lower ploughing costs.

The semi-mounted reversible EuroTitan

The EuroTitan from LEMKEN allows four adjustments to furrow width from 33 to 50 cm meaning working widths of 297 to 600 cm with nine to twelve furrows. Available with the plough is the automatic no-stop overload safety system.



Robust and reliable

The strong headstock



The one-piece shock-absorbing category III or IV plough drawbar is simply adjustable for height. It protects tractor and plough headstock through absorbing larger shock loads. The headstock axle material is well-tempered. The axle runs on roller bearings and is easily lubricated. All this means great strength and long working life.

The simple draught point selection



Horizontal pull point can be raised just by moving a bolt, allowing precise weight transfer to the rear axle of the tractor. With a crawler the pull point is fixed very low for equal loading of the tracks. This means that for all types of tractor optimum tractive force transfer is achievable with the associated minimum wheel or track slip.



Large and manoeuvrable

The reliable reversing system



The plough is turned 180° precisely and shock-free by two telescopic cylinders and the smooth operation means required hydraulic working pressure is low. Precise vertical angle settings are per adjuster screws for each side. The robust plough stands mean the plough can be simply detached in transport position and fits compactly into the implement shed.

The large clearance



A large amount of free space between tractor and headstock enables turning angles of up to 90°, increasing manoeuvrability on headlands and substantially simplifying ploughing operations with dual-wheeled tractors. Axle of turnover mechanism and wheel axle co-ordinate well for quick turns simply carried out with highest stability, even on narrow headlands in hilly fields.



Consistently perfect results

The width adjustment

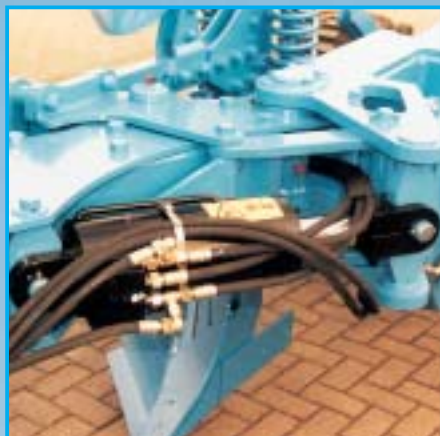

Furrow width of the semi-mounted reversible Vari-Titan can be steplessly adjusted between approx. 30 to approx. 55 cm for the best possible quality of ploughing at all times. This individual matching of working width to soil type, moisture conditions and plough depth is ideal for arable cultivation demands. The system also means that tractor power can be exploited to the full. Working width is steplessly adjustable with both front and rear plough sections via double-acting hydraulic cylinders.

The wear-free Vari attachment system

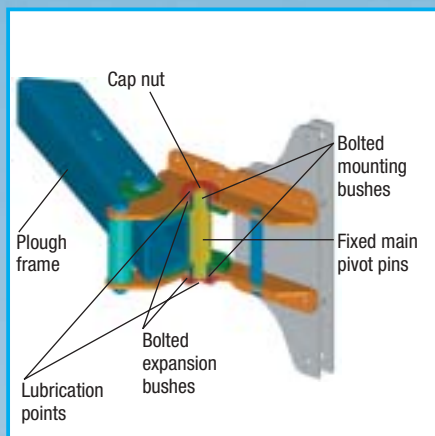

The main pivot pin of the Vari width adjustment bracket is fitted with bushes and fixed to the frame plates so that it cannot turn. The Vari pivot bracket is also equipped with securely tightened collar bushes. A long working life is guaranteed for the width adjustment pivot though these bushes running one within the other, offering unique levels of wear resistance even under hardest working conditions. Every component can be individually exchanged when required.

The ploughshare adjustment bracket



The EuroTitan adjustment brackets are bolted solidly to the frame giving great strength and reliable solidity with a high standard of precision. Loosening the central bolt and withdrawing the positioning bolt allows four different working widths to be selected from, a rapid and simple operation. Other equipment such as skimmers or disc coulters are automatically adjusted at the same time.



Details for all conditions

The articulated frame



The Vari-Titan semi-mounted reversible plough is notable for its perfect adjustment to field surfaces, even on hilly ground. The lubricated joint between the front and rear plough frames enables pivoting to maintain ploughing depth as well as to follow direction of travel. The pivot bolt is mounted in highly-tempered exchangeable guide elements. During the turning of the plough bodies the frame linkage is automatically locked by double-acting cylinder. This lock is released after the plough goes back into the ground. Through this articulated frame and the simple depth adjustment with pin, working depth is always exactly maintained across the total plough width.

The adjustment of front furrow width



During in-furrow ploughing, front furrow width is adjusted via spindle. The same spindle can be used during on-land ploughing to alter tractor-furrow distance.

The consistent working depth



The exact setting of ploughing depth can be finely tuned without tools at the wheel axle as well as by moving the appropriate pin at the rear support wheel. When the plough is set into the ground the rear support wheel is brought automatically into working position thus making impossible an undesirable forward-swinging of the wheel on uneven ground.



On-land today / in-furrow tomorrow

The on-land adjustment



The semi-mounted reversible Vari-Titan plough can be rapidly changed from on-land to in-furrow mode. The adjustment system on the front turning mechanism allows on-land ploughing with tractors up to 3.80 m wide.

The front support wheel



The front support wheel is fitted inside the plough frame and this positioning makes the Vari-Titan especially easy to manoeuvre on headlands in that there is no projecting support wheel to make turning more difficult. The working depth of the front plough element can be adjusted without tools at the wide (400/60-15,5) front wheel. The wheel automatically swings over during the plough turning procedure and locks automatically into the new position. The large diameter of the wheel ensures that it keeps revolving, even in difficult conditions.

The strong plough frame



The robust square-tube frame of micro-alloy fine-grained 10 mm steel is notable for its light weight, superior strength and long working life. The frame plates for the mounting of the adjustment brackets are bolted to the frame giving exact precision and long-term solidity.



Easy operation for highest performance

The operating terminal



Electronic control of the Titan plough brings, through its optimum headland management of repetitive actions during headland operation, a clear reduction in operator workload. The sequential headland actions can be programmed on a time basis with the programmed implement functions automatically executed according to time or distance.

The plough on the headland



On reaching the headland the front plough frame is first raised at the front and then the back. At the same time the plough is slightly turned out of the ground. Finally, the rear plough frame is lifted and the frame link locked. Through this time-based raising or lowering the often very large operational triangle on the headland with big ploughs can be reduced substantially. For optimum operation of the Titan 10 with electronic plough control, load-sensing hydraulics on the tractor is an advantage.

The rear plough frame



As well as allowing very good adjustment to the contours of the field surface and enabling the front frame to follow downward slopes first, the joint between the plough frames also enables separate raising of the rear plough frame through the electronic plough control. This allows, for instance, the ploughing in one direction with 12 furrows and in the other with eight. The support wheel (10,8/80-12) serves for depth guidance of the rear plough frame.



The economic plough body

The Dural body



The plough body is tempered and thus very strong. Each share is adjustable for pitch and thus always allows a good entry of the plough. The smooth progression from share to mouldboard and the low-resistance offered by the shape of the overall plough body reduce tractive force requirements even more.

The slatted mouldboard slats are of thick completely hardened special steel and individually exchangeable. The attachment bolts are deeply countersunk giving guaranteed secure fixing of the slats, even over extremely long service. The slatted mouldboards and conventional mouldboards are based on the same plough body.

The mouldboard components are of hardened special steel with the shape designed to reduce wear and with no bolts in the main wear zone. The extra large shin is detachable and thus cost-efficiently replaceable.

The shares



The shares comprise separate component plates of micro-alloy boron-steel. Overlapping design avoids roots or other foreign objects being caught. Tight fitting and firm attachment guarantees, wear resistance and reliability against breakage.

The wear zones of the share wings are much larger than with conventional shares and this reduces overall wear. The strength, the material and the design of the interchangeable points guarantee reduced wear and good plough penetration.

A special hard metal coating on the share point gives a length of working life unknown up until now and greatly improves cost-efficiency. The coating of the share points on one side and underneath gives a self-sharpening effect.

Good and safe in field and on road

The body components

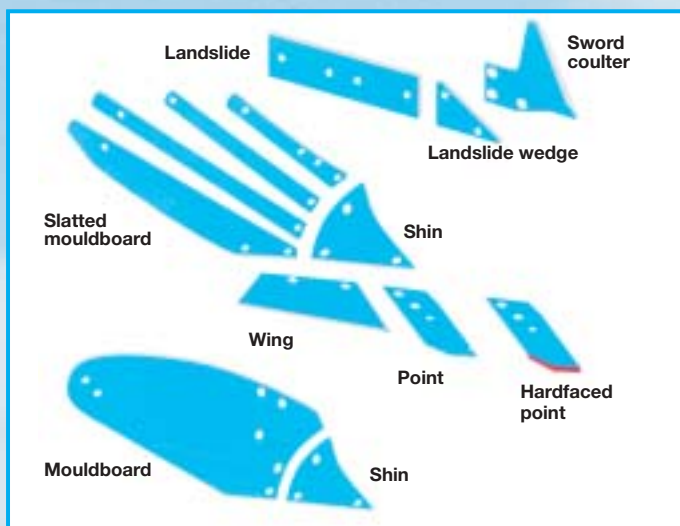

The landslide are extra-broad with the large surface area offering better plough guidance. They can be turned and reversed to give four different wear positions.

The sword coulters offers a substantially larger wearing surface for optimum exploitation. The attachment points lie in the shadow of the cutting edges and are thus protected from wear and damage. The open angles of the cutting edges running backwards and upwards leave no place where stones or roots can jam.

The running gear



The generously dimensioned wheels for the semi-mounted plough minimise ground pressure during work and offer the required security in road transport. The wheels are fitted with 38x20.0-16,1 or 405/70 R 20 tyres.

The Titan is turned into mid-position and locked by two locking valves for rapid and safe road transport. Just like a single axle trailer, the plough can then be pulled safely behind the tractor with tractor and plough effectively protected from stress forces. The LEMKEN Titan can be ordered with air or hydraulic brakes.

Ready for action when the going gets tough

The skimmers

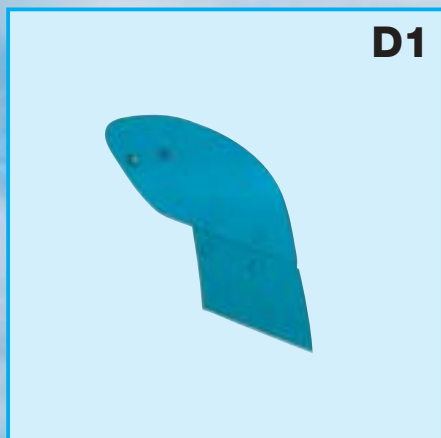

The special skimmers D1, M3 and M2 help give a clean ploughed surface, even where there's a lot of organic trash to be buried. Working depth is rapidly and simply adjusted by pin. The row of holes in the skimmer leg allows exact and equal positioning and thus consistent performance by all the dung skimmers. The skimmers D1 and M2 can be fitted with tailpieces if required.

The disc coultter



The plain 500 mm diameter disc has mouldings on the sides which ensure that it keeps turning even when cutting through large amounts of organic material. Depth adjustment is through vertical swivelling of the disc coultter arm through its toothed grip, where it is secured in the desired position by a bolt. The adjustable disc bearing which is plain on the plough-side is double-sealed against dirt ingress. The large clearance between coultter and coultter arm helps give blockage-free ploughing.

The trashboards



The trashboards are mounted directly on top of the mouldboard and multi-adjustable. These plates ensure blockage-free work and clean burying of plant material.



Adjustments: no-tool and very quick

The flat stalk



The flat rectangular form of the stalk allows secure attachment of the skim frog with no twisting of the skimmer. All share and mouldboard variants can be interchanged without problem because the frog suits all skimmers. Because there are only two bolts to loosen, the stalk can also be quickly dismantled for ploughing without skimmers.

The angle adjustment



Available for the Vari-Titan with shear bolt overload system is a single-body angle quick adjustment for the skimmer allowing exact control of the depositing of organic mass.

The working depth adjustment



The skimmers of the Titan with automatic overload security system can be adjusted on the beams. Adjustment of working depth is with pins with no tools required. If an adjustment of the throw angle is desired, round legs can be fitted which are secured in the attachment by bolt.



Non-Stop trip mechanism

The gentle shock-free tripping



The LEMKEN Non-Stop trip mechanism features short, doubled, coil springs which guarantees high tripping and re-entry forces.

The special design means the effective force on the share point at tripping continuously reduces and increases accordingly during re-entry.

Trips forces at the share point

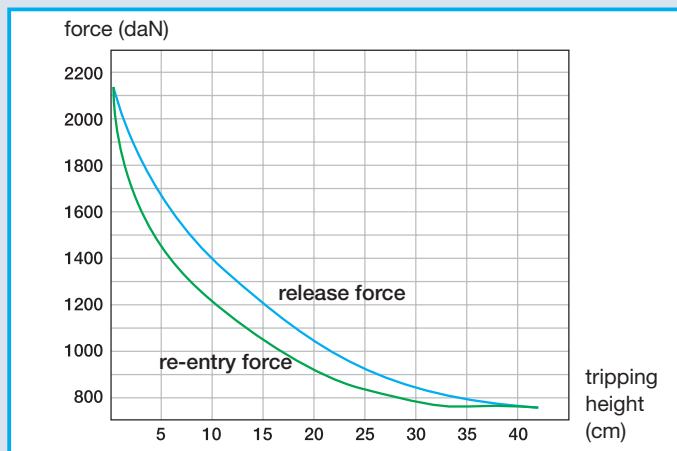

The plough body trips gently and carefully whereas the re-entry takes place with exceptionally powerful force. No shock forces are thus applied to the plough frame or tractor.

The presetting of the springs is steplessly adjustable. Thus tripping and re-entry can be optimally adjusted to suit the actual soil conditions.



Ideal in stony soils

Reaction at obstacles

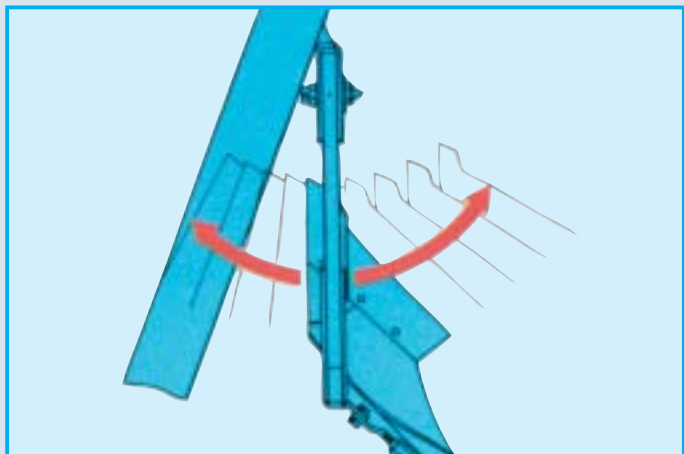

When the plough makes contact with an obstacle the elastic, high quality tempered spring-steel beams and body legs are able to „sidestep“ to an unusual degree. During this movement each beam is firmly guided so that there is no way it can spring out of its mounting. Both leg bracket and beam with the roller are bolted and not welded. This means great strength and long life for the working elements of the overload safety system.

Extra security

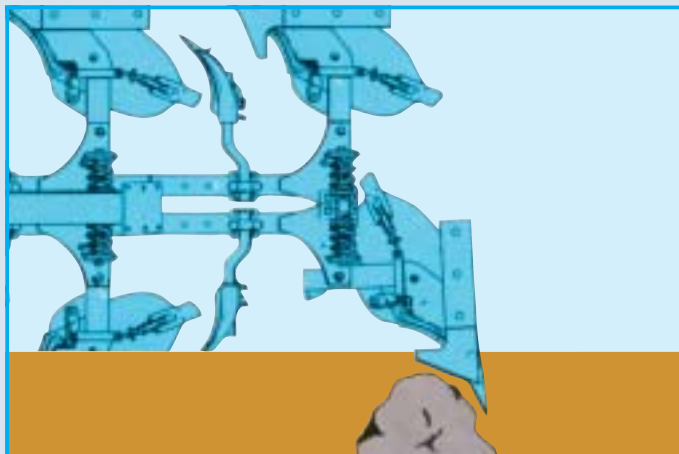

Even where the share point is firmly caught under a stone, tree root or rock ridge, all LEMKEN ploughs are protected against damage by an additional shear bolt device as standard. A new shear bolt is quickly and easily replaced and the work can restart as easily as that.



Technical data

Box section
frame

□ 180 x 180 x 10 mm



6●3



6●3 + 1

	EuroTitan	Vari-Titan	EuroTitan	Vari-Titan
Working width (apprx. cm)	297-450	270-495	330-500	300-550
Weight (apprx. kg)	4.593	5.070	4.790	5.320
Max. kW/hp	231/315	231/315	257/350	257/350
Interbody clearance (cm)	100	100	100	100
Underframe clearance (cm)	80	80	80	80
X-version*	x	x	x	x

Box section
frame

□ 180 x 180 x 10 mm



7●3

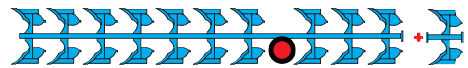

7●3 + 1

	EuroTitan	Vari-Titan	EuroTitan	Vari-Titan
Working width (apprx. cm)	330-500	300-500	363-550	330-605
Weight (apprx. kg)	4.810	5.340	5.007	5.570
Max. kW/hp	257/350	257/350	283/385	283/385
Interbody clearance (cm)	100	100	100	100
Underframe clearance (cm)	80	80	80	80
X-version*	x	x	x	x

Box section
frame

□ 180 x 180 x 10 mm



8●3



8●3 + 1

	EuroTitan	Vari-Titan	EuroTitan	Vari-Titan
Working width (apprx. cm)	363-550	330-605	396-600	360-600
Weight (apprx. kg)	5.027	5.590	5.224	5.820
Max. kW/hp	283/385	283/385	309/420	309/420
Interbody clearance (cm)	100	100	100	100
Underframe clearance (cm)	80	80	80	80
X-version*	x	x	x	x

* Approx. 15% weight addition in the case of the X-model (with automatic no-stop overload security system).

All information, measurements and weights are subject to continuous technical further development and are therefore non obligatory. Information regarding weights always refers to the basic model. The right is reserved to make alterations.